

RAILING INFILL PANELS

TABLE STANDARD MESHES

0ga.	1 1/2"	diamond mesh
6ga.	2"	diamond mesh
1ga.	1"	square mesh
0ga.	1 1/2"	square mesh
8ga.	2"	square mesh
4" dia.	2"	square mesh
8" dia.	2"	square mesh

Note: Other custom meshes in various gauges and patterns available.

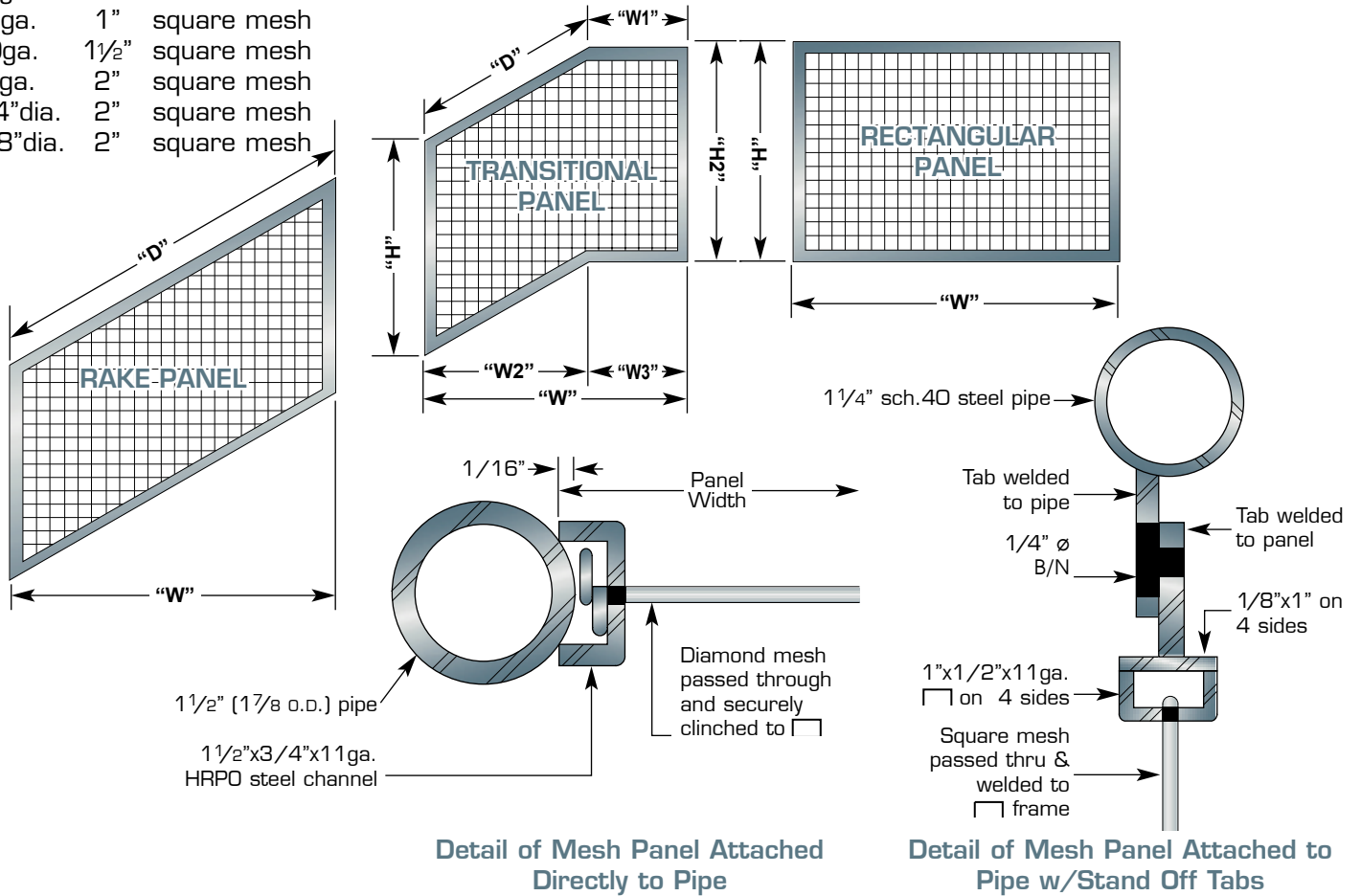

FRAMING OPTIONS

Illustrations shown 1/2 scale

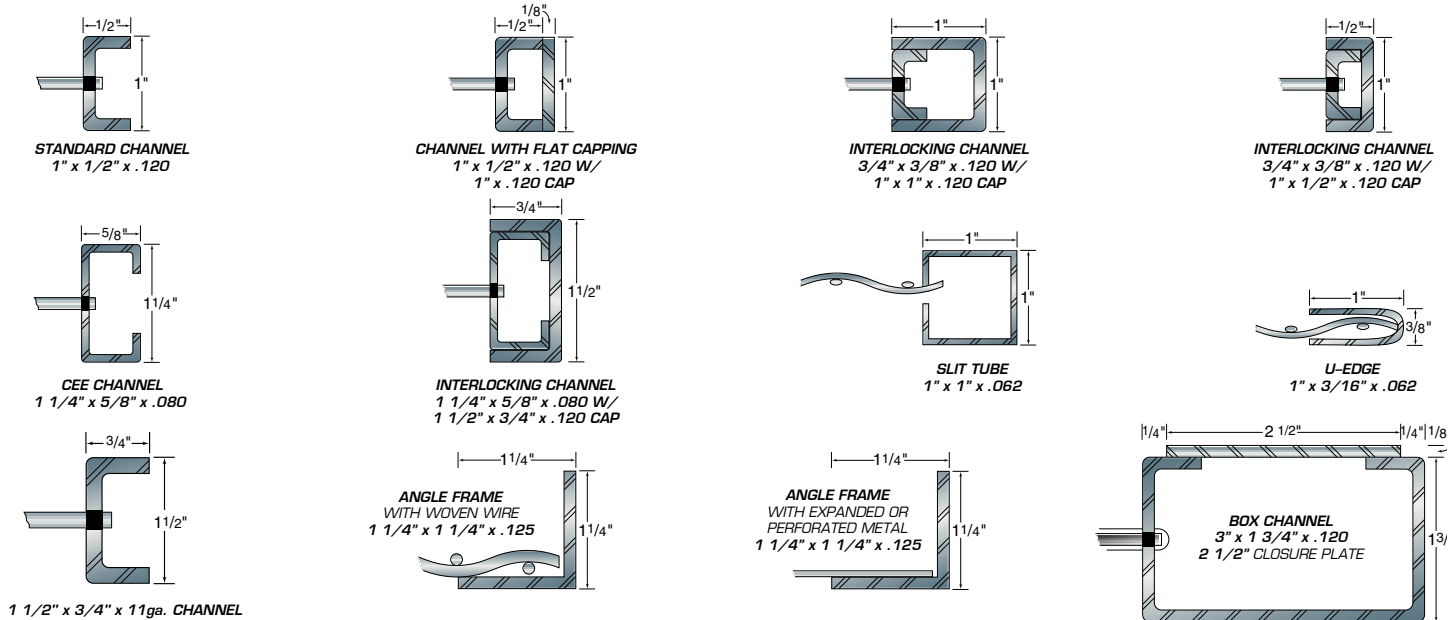

PHONE: (732) 661-2001



FAX (732) 661-2003

